

PETROMETALIC

Fluid Control Solutions

Pumps & Boosters

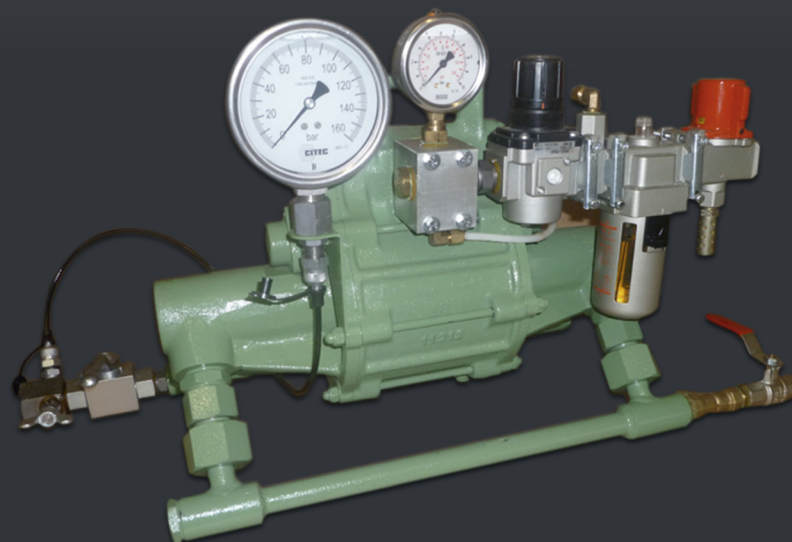

Petrometalic SA

32, rue de l'Ermitage

78000 VERSAILLES

www.petrometalic.com

packers@petrometalic.com

SOMMAIRE

Hydraulic pump 2

 S218GJC 2

Construction pumps 4

 SP400..... 4

 SPC50 / SPC90..... 5

 2-component resin pump 6

HP hydropneumatic pumps 7

 SP2300CS..... 7

 SP2300 / SP216 8

 Le Touquet..... 9

 PS4..... 10

Hand pumps 11

 SM3 11

 S525 12

 Test hand pump 13

Gas pumps, air amplifier 14

 P4B..... 14

 SAG700 15

 Air amplifier..... 16

Warehouse – Workshop..... 17

Exclusive dealer France



Exclusive dealer France



CONTACTS :



PETROMETALIC headquarters
 32 rue de l’Ermitage
 F - 78000 Versailles Cedex
 Tel : +33 1 39 23 96 70
 Fax : +33 1 39 23 96 71
 CEO : M. Philippe Mazurel
 direction@petrometalic.com

M. Jean-Bernard JANOWCZYK
 CTO
 Tel. + 33 3 27 72 06 26
 Fax +33 3 27 72 06 31
 dev@petrometalic.com



PETROMETALIC Cambrai
 11 rue de Ecluses de Selles BP 287
 F - 59400 Cambrai cedex
 Tel : 33 (0) 3 27 72 06 60
 Fax : 33 (0) 3 27 72 06 61
 CFO : Geneviève Leroy
 daf@petrometalic.com

Mme Elisabeth BONNEVILLE
 Sales France & Export
 Tel. +33 3 27 72 06 24
 Fax +33 3 27 72 06 31
 packers@petrometalic.com

Mr Didier RENU
 Sales
 Tel. +33 3 27 72 06 20
 Fax +33 3 27 72 06 31
 packers@petrometalic.com



S218 GJC HIGH FLOW HYDRAULIC PUMP

Pneumatic Control

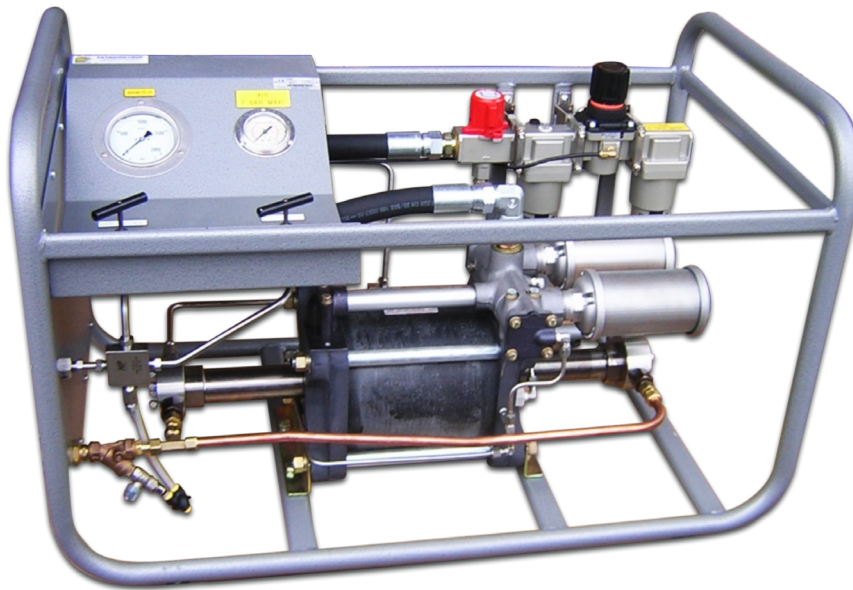

Ratio : 45 Max. pressure : 310 bar Max. flow: 39,7 l/mn	Ratio : 65 Max. pressure. : 448 bar Max. flow: 32,2 l/mn	Ratio : 200 Max. pressure. : 1380 bar Max. flow: 8,60 l/min
--	---	--

Technical data

- ▶ Drive fluid : air, nitrogen, etc.
- ▶ Fluid to compress : water, oil, hydrocarbons, etc.

Principle

The S218 GJC pump transforms a low pressure fluid into a high pressure fluid via an working fluid whose pressure can be adjusted thanks to a pressure gauge. It is particularly suitable for hydrostatic tests, machine operations, battery charging as well as to deep water operations.

By controlling the inlet air pressure, the fluid output pressure can be adjusted according to the pump's pressure ranges..

Benefits

- ▶ The S218 GJC uses lubricated compressed air as an energy source :
- ▶ it can therefore be used in hazardous locations
 - it is suitable for large thermal amplitudes
 - it is robust and suitable for hostile environments.
 - it quickly reaches the desired pressure and maintains it with minimal energy consumption, without thermal effect on the fluid or moving parts
 - it automatically restarts to restore the equilibrium pressureThe pump parts in contact with the fluid are made of stainless steel and chrome, compatible with most non-corrosive fluid materials.
- ▶ Antifreeze device.
- ▶ May be operated with gas wellhead.

S218 GJC HIGH FLOW HYDRAULIC PUMP

PERFORMANCE & TECHNICAL DATA

S-218-GJC-45

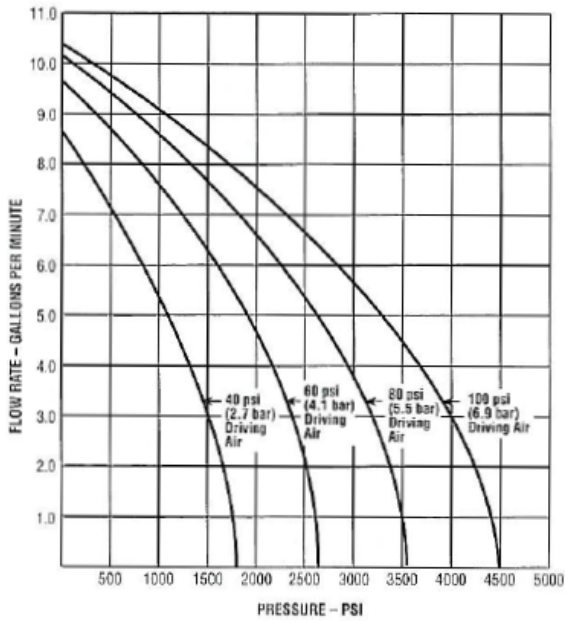

S-218-GJC-65

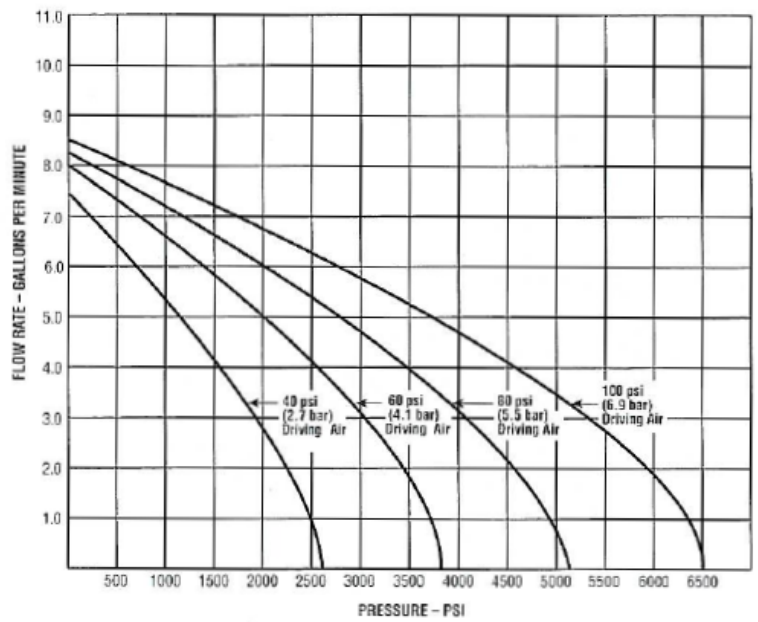

DISCHARGE CAPACITY - CUBIC INCHES (LITERS) PER MINUTE - APPROXIMATE						
Based on 350SCFM of driving air at 100 psi (9.9 Std. Cu. Meters driving air at 6.9 bar)						
DISCHARGE PRESSURE						
Pump Model No.	0 psi (0 bar)	4000 psi (276 bar)	8000 psi (552 bar)	12000 psi (828 bar)	16000 psi (1104 bar)	20000 psi (1380 bar)
S218-200D (200:1 ratio)	525 (8.60)	510 (8.36)	470 (7.70)	375 (6.15)	230 (3.77)	-

S-218-200D

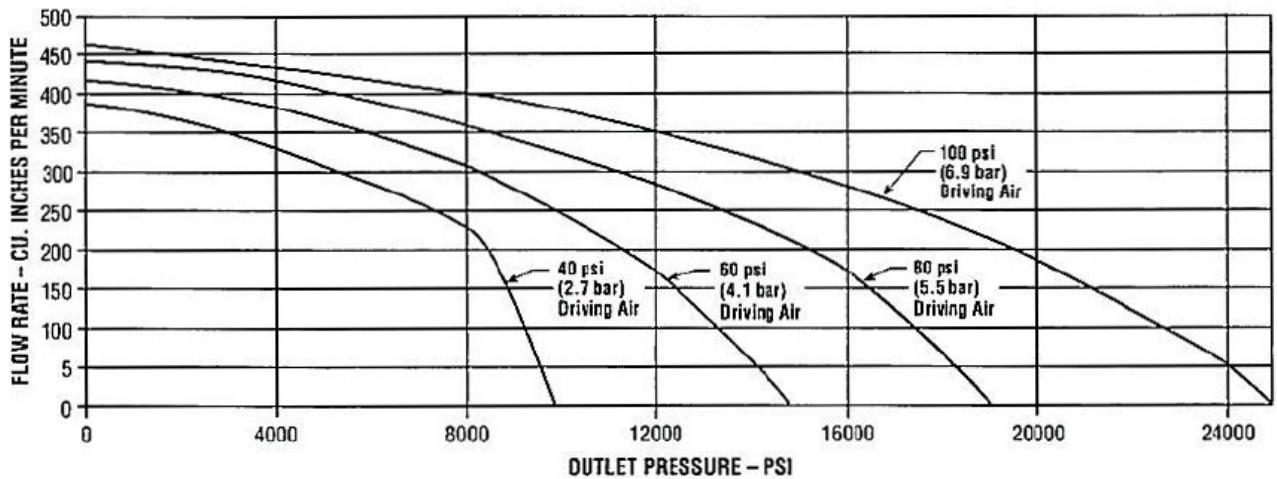

SP400 BOOSTER

Double effect portable test pump

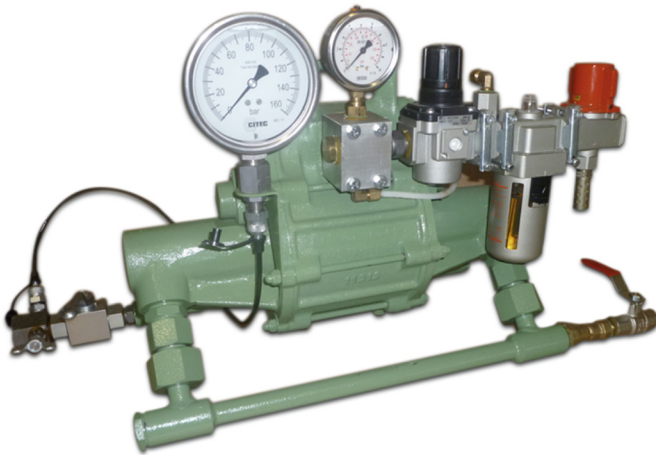

SP400 without chassis
 Dimensions : 460 x 250 x 350 mm
 Approx. weight. : 25 kg

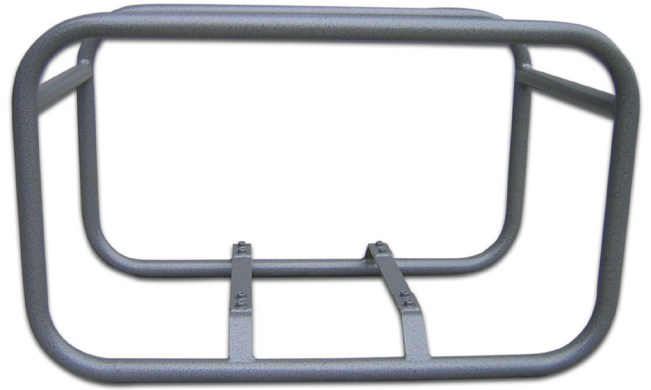

Chassis for SP400
 Dimensions : 780 x 430 x 480 mm
 Approx. weight. : 32 kg

4 ratios >>	Ratio : 13	Ratio : 24	Ratio : 55	Ratio : 70
Max. pressure	90 bar	168 bar	385 bar	490 bar
Max. flow	15 l/min	13 l/min	8,5 l/min	6,5 l/min
Volume displaced by cycle	100 cm ³	56 cm ³	25 cm ³	20 cm ³

Technical data

- ▶ Working fluid : air, azote, etc...
- ▶ Fluid to pressurize : water, oil, compatible chemical fluids, etc...

Principle

The SP400 pump transforms the LP component into an HP component through the working fluid. The pressure can be set thanks to a manual pressure regulator.

Benefits

- ▶ Lightweight portable pump, well suited for building sites where large pumps cannot be installed..
- ▶ Easy and quick maintenance.
- ▶ Fully equipped, ready to use and CE certified.

Options

Pressure recorder, High and low pressure flexible hose, protection frame, etc...

SPC50 – SPC90 GROUT PUMPS

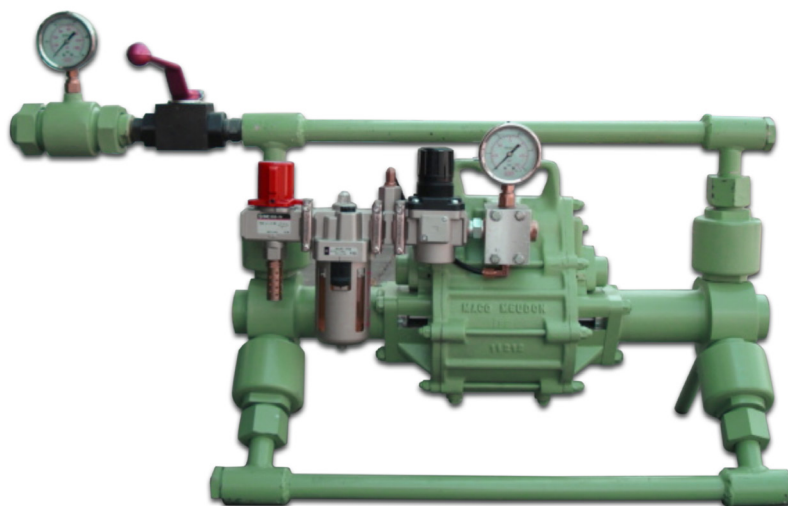

Technical data

- ▶ Dimensions : L 610 mm, H 420 mm, larg. 380 mm
- ▶ Approx. weight. : 34 kg
- ▶ Available in 2 versions : **SPC50** (50 bar) ou **SPC90** (90 bar)

Principle

The SPC 90 pump transforms the LP component into an HP component by means of a drive fluid whose pressure can be set thanks to a manual pressure regulator.

Avantages

- ▶ Lightweight, sturdy, compact, easily transportable, well suited for building sites where large pumps cannot be installed.
- ▶ Easy and quick maintenance.
- ▶ Fully equipped, ready to use and CE certified.

	SPC50	SPC90
Max. pressure	50 bar	90 bar
Max. flow	2 m ³ /h	1 m ³ /h
Ratio	8.3/1	13/1
Volume delivered by piston stroke	178 cm ³	98 cm ³

2-COMPONENT RESIN PUMP

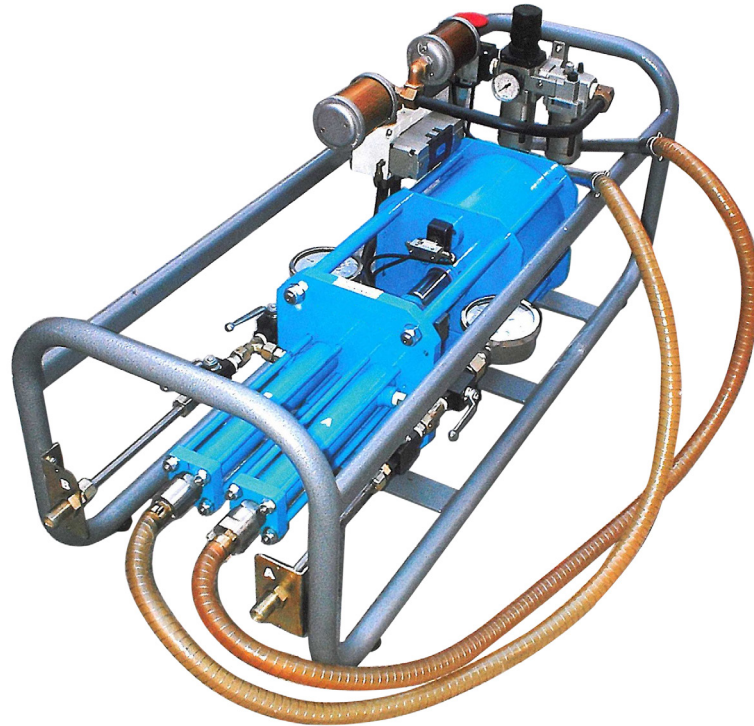

PNEUMATIC VERSION

Technical data

- ▶ Air pressure : max. 7 bar
- ▶ Injection pressure : max. 160 bar
- ▶ Injection flow : 18L/mn*
- ▶ Sound level : 45dB (A)
- ▶ Dimensions : 1120 x 410 x 430mm
- ▶ Net weight : 75kg

* free flow

HYDRAULIC VERSION

Technical data

- ▶ Hydraulic flow : max. 30L/mn
- ▶ Hydraulic pressure : max. 80 bar
- ▶ Injection pressure : max. 160 bar
- ▶ Injection flow : 18L/mn*
- ▶ Sound level : 55dB (A)
- ▶ Dimensions : 1120 x 410 x 430mm
- ▶ Net weight : 80kg

* free flow

SP2300 HYDROPNEUMATIC PUMP WITH SEPARATE BODY

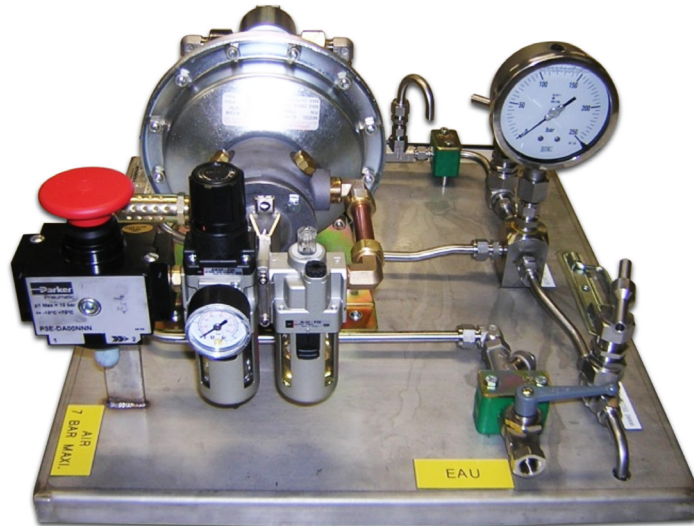

Technical data

- ▶ Dimensions : L 520 x W. 510 mm x H 300 mm
- ▶ Approx. weight : 24 kg
- ▶ 10 ratios
- ▶ Max. pressure: 2300 bar

Principle

The design of the SP2300 version S216JS with separate body dissociates the working fluid section from the pump: it is specifically designed to convey non contaminated or food grade fluids.

Other model : the SP2300 S216 JSN is designed for use in laboratories and cleanrooms. Unlike the S216JS model, the JSN version consumes clean and dry air. The working fluid section is equipped with self-lubricating joints.

These pumps can transform a low pressure demineralized water in high pressure fluid through a working fluid (current exemple: breweries). Simply adjusting the air regulator progressively provides the desired pressure. When it is reached, the pump stops and the pressure is maintained in the high pressure circuit without any energy consumption. Petrometalic offers this pump mounted on a deck, equipped with both a working fluid line and a pressurized fluid line, ready for use.

Bare pump - technical data

Ratio	Outlet pressure bar	Fitting NPT	Dis-placed volume by cycle in cm ³	Outlet fluid pressure in bar																	
				0	17	35	48	70	105	140	175	210	280	350	525	700	1050	1400	2100		
				Performance - Approx. flow in l/min																	
10/1	70	3/8	53	7,94	9,17	7,92	5,30														
18/1	126	3/8	28,5	8	7,20	6,6	6	5,3	3,5												
30/1	210	3/8	17	5,5	4,7	4,4	4,20	3,9	3,4	2,5	2	0,7									
45/1	315	3/8	11,5	4,85	3,89	3,67	3,49	3,27	3,02	2,67	2,31	1,99	1,13								
60/1	420	3/8	8,5	3,5	3,1	3	2,9	2,8	2,5	2,3	2	1,8	1,4	1							
88/1	616	3/8	6	2,8	2,3	2,2	2,1	2,1	1,9	1,8	1,7	1,6	1,5	1,2	0,9						
125/1	862	1/4	4,5	2,1	1,7	1,6	1,5	1,5	1,4	1,3	1,2	1,1	1	0,9	0,7	0,6					
160/1	1120	1/4	3	1,3	1,3	1,2	1,2	1,2	1,1	1,1	1	1	0,9	0,9	0,7	0,6	0,3				
237/1	1660	1/4	2	0,86	0,85	0,81	0,80	0,78	0,77	0,75	0,73	0,70	0,67	0,62	0,55	0,49	0,32	0,14			
335/1	2345	1/4	1,5	0,60	0,58	0,57	0,55	0,54	0,54	0,52	0,50	0,49	0,49	0,47	0,42	0,37	0,29	0,22	0,09		

LE TOUQUET HIGH PRESSURE PUMP Power Unit

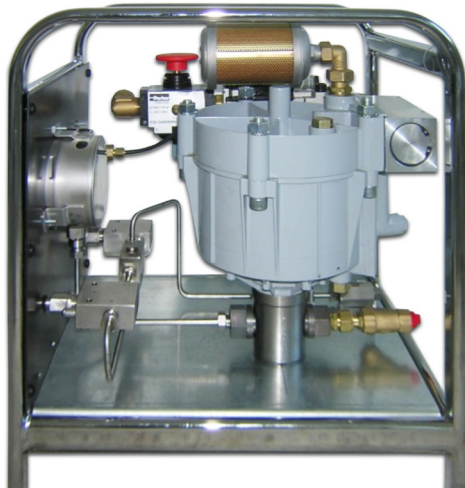

Technical data

- ▶ Dimensions: 440 x 440 x 470 mm
- ▶ Approx. weight: 25 kg
- ▶ 3 ratios : 30/1, 100/1, 300/1
- ▶ Max. pressure: 2100 bar
- ▶ Available in 2 versions: **full tubular frame mount** (pictures above) or **standalone pump**

Principle

These pumps use compressed air (dry air) as an energy source to pressurize fluids (water, oil, compatible chemical fluids) at high pressures and automatically maintain these pressures without consuming any energy..

Benefits

- ▶ simple installation / no maintenance / explosion-proof
- ▶ static pressure maintained (without energy consumption)
- ▶ reduced footprint
- ▶ no metal friction during movement (HP/LP pistons and slide-valve)

Technical data for the standalone pump

Performance calculated for a working fluid pressure of 7 bar

Ratio	Nominal output pressure in bar	Input fitting NPT	HP cubic capacity in cm3	Outlet pressure in bar																
				0	50	100	150	200	210	300	400	500	600	700	1000	1500	1750	2000	2100	
				Performance - Approx. Flox in l/min																
30/1	210	1/2	48	8,2	6,4	5,4	4,5	3	0											
100/1	700	1/2	27	2,9	2,7	2,4	2,25	2,1	2	1,8	1,5	1,3	0,9	0						
300/1	2100	3/8	4,7	0,85	0,83	0,8	0,78	0,75	0,75	0,7	0,68	0,64	0,61	0,58	0,54	0,44	0,34	0,2	0	

PS4 INTERCHANGEABLE MODULAR HYDROPNEUMATIC HIGH PRESSURE PUMP

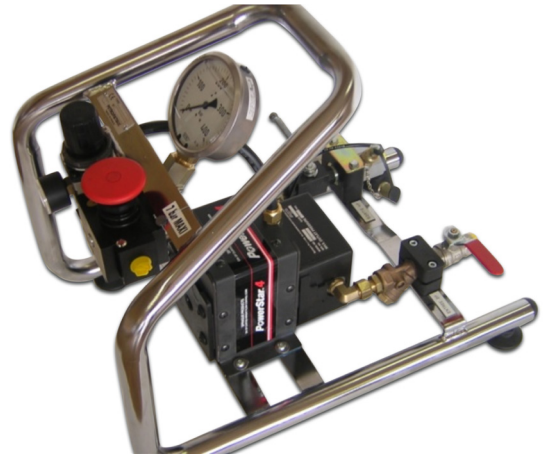

Technical data

- ▶ Dimensions: 540 x 370 x 430 mm
- ▶ Approx. weight: 14 kg
- ▶ 8 ratios for a same engine module
- ▶ Modular system: higher flow rates by addition of a second HP module.
- ▶ Max. pressure: 2300 bar
- ▶ Available in 2 versions: **tubular frame mount** (pictures above) ou **standalone pump**

Principle

These pumps use compressed air (dry air) as an energy source to deliver fluids (water, oil, corrosive chemical fluids) at high pressures.

Pump - technical data

Ratio	Outlet pressure in bar	Fitting in out NPT	Displaced volume by cycle in cm ³	Fluid pressure in bar															
				0	6,9	13,8	27,6	55,2	83	138	200	275	345	410	550	690	830	1380	2070
				Performance - Approx flow in l/min															
5/1	35	3/4» 1/2"	39	14	14	13	3,8												
double effect			25,2	25,2	23,4	6,84													
10/1	70	3/4» 1/2"	19.5	11	11	10	7,5	2											
double effect			19,8	19,8	18	13,5	3,6												
21/1	147	1/2» 3/8"	9.8	6,6	6,3	6	5	3,3	2,5	0									
double effect			11,9	11,3	10,8	9	5,94	4,5	0										
34/1	238	1/2» 3/8"	6	3,8	3,8	3,7	3,5	3,4	2,8	2	0,5	0							
double effect			6,84	6,84	6,66	6,3	6,12	5,04	3,6	0,9	0								
64/1	448	1/2» 3/8"	3.2	2,4	2,4	2,3	2,2	1,8	1,5	1,3	1,1	0,9	0,7	0,2					
double effect			3,9	4,32	4,14	3,96	3,24	2,7	2,34	1,98	1,62	1,26	0,36						
114/1	798	3/8» 9/16-18NBS	1.8	1,3	1,3	1,3	1,2	1,2	1,1	0,98	0,87	0,85	0,82	0,81	0,65	0,22			
double effect			2,34	2,34	2,34	2,16	2,16	1,98	1,76	1,57	1,53	1,48	1,46	1,17	0,4				
203/1	1421	3/8» 9/16-18NBS	0.98	0,7	0,7	0,6	0,6	0,6	0,5	0,5	0,5	0,5	0,47	0,45	0,43	0,4	0,37	0	
double effect			1,26	1,26	1,08	1,08	1,08	0,9	0,9	0,9	0,9	0,85	0,81	0,77	0,72	0,67	0		
333/1	2331	3/8» 9/16-18NBS	0.65	0,33	0,33	0,32	0,32	0,3	0,29	0,29	0,28	0,27	0,27	0,25	0,23	0,22	0,2	0,13	0,02
double effect			0,59	0,59	0,58	0,58	0,54	0,52	0,52	0,5	0,49	0,49	0,45	0,41	0,4	0,36	0,23	0,04	

SM3 PORTABLE TEST HAND PUMP

Hydropneumatic mini-pump with frame mount

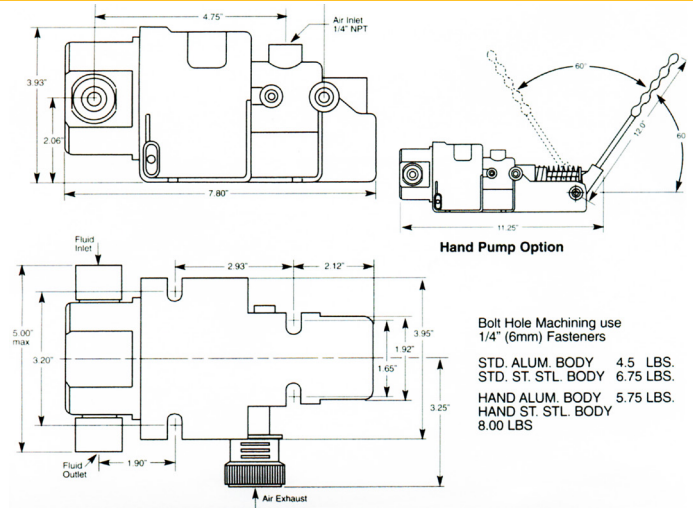
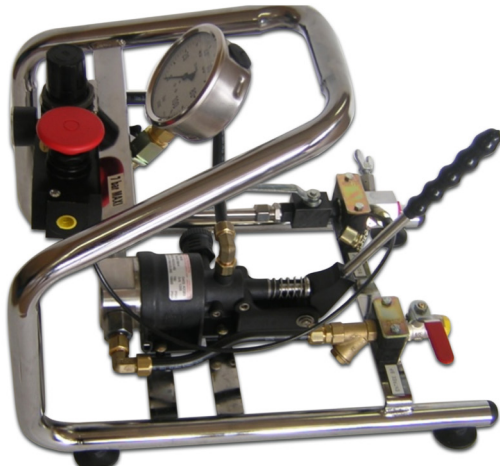

Technical data

- ▶ Dimensions: 540 x 370 x 430 mm
- ▶ Approx. weight: 12 kg
- ▶ 8 ratios
- ▶ Max. output pressure: 1552 bar
- ▶ Available in 3 versions: **tubular frame mount / stainless steel** (picture above), **tubular frame mount / aluminium** or **standalone pump**.
- ▶ Option : manual version

Principle

These mini-pumps use compressed air (dry air) as energy source for liquid (water, oil) at elevated pressures. Good quality / price ratio.

Pump - technical data

Ratio	Outlet pressure in bar	Fitting in out in NPT	Displaced volume per cycle in cm ³	Outlet pressure in bar															
				0	7	13	24	34	69	103	138	276	414	551	689	827	1034	1379	
				Performance - Approx flow in l/min															
5/1	34	3/8» 3/8»	17	9	5,4	4,5	2,9												
10/1	69	3/8» 3/8»	8,6	7,8	5,7	3,3	2,9	2,4	0,1										
20/1	138	3/8» 3/8»	4,3	5	4,6	3,4	2,6	1,8	1,2	1	0,2								
35/1	241	3/8» 3/8»	2,4	2,6	2,3	1,9	1,6	1,4	1	0,8	0,6								
60/1	414	3/8» 3/8»	1,4	1,6	1,4	1,3	1,1	1	0,5	0,4	0,3	0,3							
100/1	689	1/4»NPT x HP	0,86	0,9	0,9	0,8	0,8	0,8	0,6	0,5	0,3	0,2	0,2	0,1					
150/1	1034	1/4»NPT x HP	0,57	0,6	0,6	0,6	0,6	0,5	0,4	0,4	0,3	0,2	0,2	0,1	0,1	0,1	0,1		
225/1	1552	1/4»NPT x HP	0,37	0,4	0,3	0,3	0,3	0,3	0,3	0,3	0,2	0,1	0,1	0,1	0,1	0,1	0,1	0,06	0,05

HIGH PRESSURE HAND PUMP S525 Power Unit

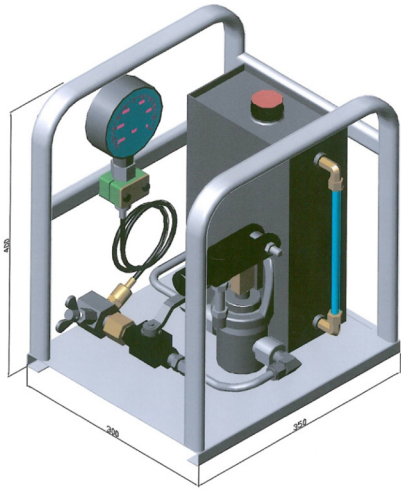

Technical data

- ▶ Dimensions: 350 x 300 x 400 mm
- ▶ Approx. weight: 15 kg
- ▶ Frame mount hand pump, fully equipped and ready for use
- ▶ Tank capacity: 5L
- ▶ Max. pressure: 1200 bar
- ▶ Available in 2 versions : **frame mount** (picture above) or **standalone pump**
- ▶ Other tank capacities on request

Principle

This single acting piston pump is adapted to hydraulic tests and other industrial applications that need little volumes at high pressures.

The parts of the pump in contact with the fluid are in stainless steel. The pump can consequently transport de-ionized water.

The tank mounted on the above picture is in stainless steel.

MODEL	Max. Outlet Pressure (bar)	Inlet Fitting (NPT)	Outlet Fitting (NPT)
S-525-35	150	3/8 NPT	3/8 NPT
S-525-60	200	3/8 NPT	3/8 NPT
S-525-100	300	3/8 NPT	3/8 NPT
S-525-125	370	1/4 NPT	9/16-18 NBS
S-525-150	460	1/4 NPT	9/16-18 NBS
S-525-200	820	1/4 NPT	9/16-18 NBS
S-525-300	1200	1/4 NPT	9/16-18 NBS

TEST HAND PUMP WITH TANK



Technical data

- ▶ Single effect hand pump with piston
- ▶ Tank capacity : from 0L to 60L depending on version (see available versions below)
- ▶ Max. pressure : from 60 to 1200 bar depending on version
- ▶ Testing fluid : pure water, water/oil emulsion, light oil.

Principle

The hand pump with simple piston effect is ideal for **hydraulic tests**, **packers inflation** and many other industrial applications. This sturdy pump is perfectly suited for on site use.

The only thing to do is to fill up and vent the system completely. Close drain valve and vent of test piece. Then operate the plunger in order to create the required test pressure. When test procedure is completed, open drain valve before disconnecting test piece.

TYPE	FEATURES
HP UX 60	Rectangular 10 litres tank Max pressure : 60 bar
HP 300	30 litres tank Max pressure : 60 bar
HP 220	Réservoir 30 litres Max pressure : 100 bar
HP 500	30 litres tank 2 versions : Max pressures : 100 or 200 bar
HP 32/12	60 litres tank Max pressure : 600 bar
HP 32/8	60 litres tank Max pressure : 1000 bar

POWERSTAR 4B™ GAS BOOSTER BOTTLE MOUNTED

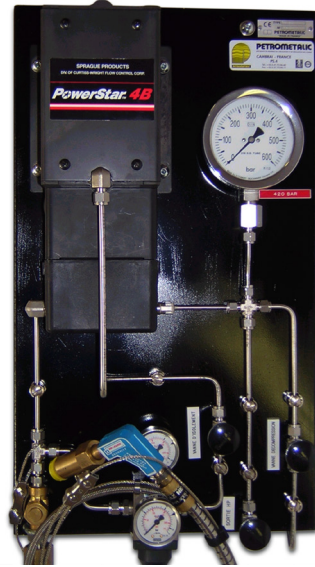
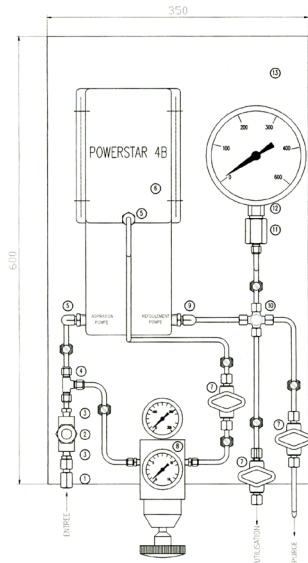

Technical data

- ▶ Dimensions: 700 x 350 x 470 mm
- ▶ Approx weight: 17 kg (hose included)
- ▶ Neutral gas booster for accumulators bladders inflation and transfer
- ▶ Energy source: dry air
- ▶ Mac. pressure: from 70 to 600 bar
- ▶ Available in 2 versions : **deck mount** (pictures above) or **standalone** booster

Powerstar P4B performance chart (air consumption of 50 SCFM / 84Nm3/h)

Model	Preload bar	Max. outlet pressure bar	Flows in NL/minute for an outlet pressure (bar) of:											
			14	28	42	56	70	140	210	280	350	420	490	560
P4BS010	7	70	75	68	63	58								
P4BS010	14	70	141	128	118	108								
P4BS034	28	234			72	71	70	60	54					
P4BS034	34	234			89	88	87	75	67					
P4BS050	28	345			45	44	41	39	37	36				
P4BS050	34	345			56	55	51	48	46	44				
P4BS080	41	552							39	36	33	31	30	
P4BS080	70	552							64	59	54	52	50	
S010P4BS010	3	72	72	66	61	56								
S010P4BS010	7	76	128	116	107	98								
S010P4BS010	14	83	240	218	201	184								
S034P4BS034	21	255			93	92	91	78	70					
S034P4BS034	28	262			122	121	120	103	92					
S034P4BS034	34	269			152	150	149	127	115					
S050P4BS050	28	372			77	75	70	66	63	61	35			
S050P4BS050	34	379			95	94	87	82	78	75	43			
S080P4BS080	41	593							66	61	56	53	52	31
S010P4BS034	7	265			51	51	50	47	42					
S010P4BS050	7	386			51	51	50	47	44	42	38			
S010P4BS080	7	614			51	51	50	48	47	45	44	42	40	38

SAG 700 BOOSTER FOR AIR AND NEUTRAL GASES

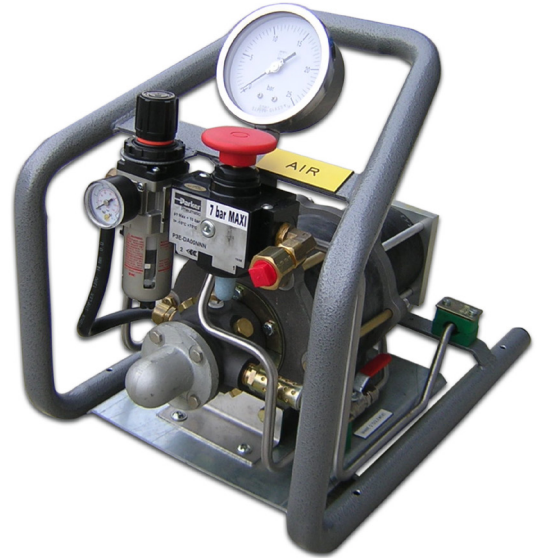
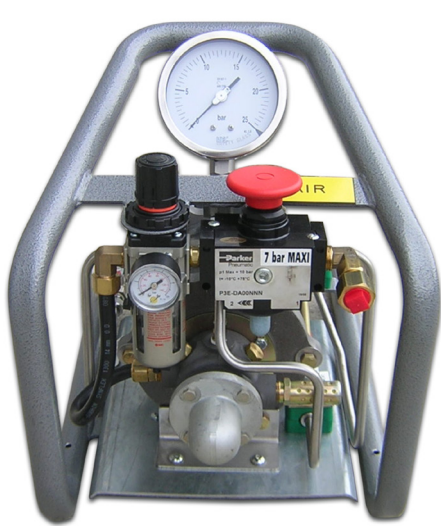

Technical data

- ▶ Dimensions: 550 x 370 x 450 mm
- ▶ 6 ratios
- ▶ Approx. weight.: 18kg
- ▶ Max. pressure: 690 bar
- ▶ The booster provides high pressures for AIR or neutral GAS, from a workshop network or from a gas cylinder.
- ▶ Piston device: Air operating according to the principle of mechanical inversion acting on the piston cycles. Principle of differential pistons.
- ▶ Available in 2 versions : **tubular frame mount** (pictures above) or **standalone booster**

Bare pump technical data

PN	Designation	Ratio	Engine air pressure bar	Preload bar	Outlet pressure bar	Air/Engine fitting NPT	I/O high pressure connector NPT	Bare pump length mm	Bare pump diameter mm	Bare pump weight kg
158001	SAG 700 S86 JN2	2/1	1,7 à 7	1,7 à 14	3,4 à 14	1/2" NPT	3/8" NPT	463	196	7,7
158003	SAG 700 S86 JN5	5/1	1,7 à 7	3,4 à 35	8,6 à 35	1/2" NPT	3/8" NPT	463	196	7,3
158005	SAG 700 S86 JN15	15/1	1,7 à 7	3,4 à 105	25,9 à 105	1/2" NPT	1/4" NPT	445	196	8,2
158004	SAG 700 S86 JN30	30/1	1,7 à 7	13,8 à 210	51,7 à 210	1/2" NPT	1/4" NPT	394	196	8,8
158009	SAG 700 S86 JN60	60/1	1,7 à 7	17,2 à 420	103 à 420	1/2" NPT	1/4" NPT	403	196	8,8
158011	SAG 700 S86 JN100	100/1	1,7 à 7	34,5 à 690	172 à 690	1/2" NPT	1/4" NPT	403	196	8,8

AIR AMPLIFIER

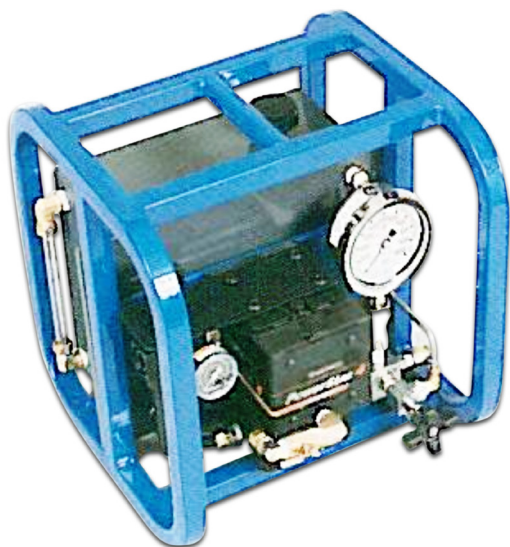

Performance Chart : AA4P4AA4 Double-ended Air Amplifier

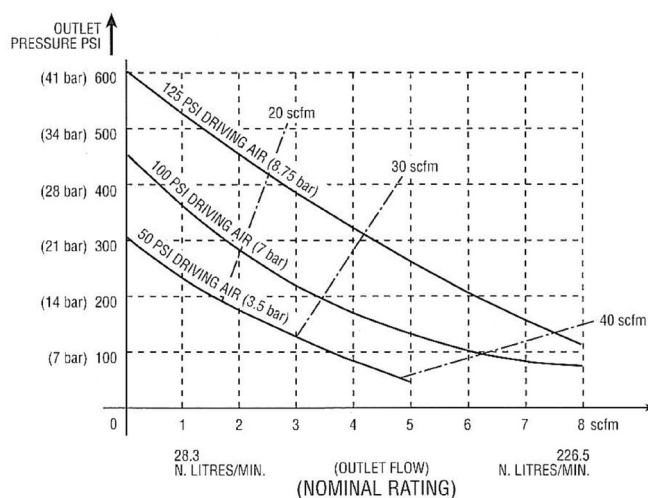

Features

- ▶ Dimensions: 550 x 370 x 450 mm
- ▶ Approx. weight.: 18kg
- ▶ 1 scfm = 28 litres
- ▶ Continuous curves : approx. flows
- ▶ Dotted lines : air consumption
- ▶ Available in 2 versions : **naked air amplifier** or **equipped with surge tank**

Principle

The powerStar 4 air amplifier develops high output pressures by applying the principle of differential areas. It is composed of 1 air motor module (P4) and 1 or 2 air amplifier modules ratio 4,5. The choice of a single or double effect unit is determined according to flow needed.

Options

Single ended unit (1 module)	Double ended unit (2 modules)
7 bars (air) : 31 bar output pressure Flow : 56 Nl/min	7 bars (air) : 31 bar output pressure Flow : 56 l/min



WAREHOUSE - WORKSHOP

WAREHOUSE

We have a **large stock of spare parts** for test pumps and accessories such as gauges, LP and HP hoses, FL and FRL, HP connectors for test bench mounting...



We have at your disposal complete spare parts lists as well as exploded view drawings of all our test pumps.

Regarding fittings, valves, HP tubes from HIP, the complete catalogs are available for download on <http://en.petrometalic.com>

WORKSHOP

The structure of our workshop enables:

- ▶ to perform **pressurizing tests**
- ▶ to perform **pump revisions and reparations.**

Our test benches:

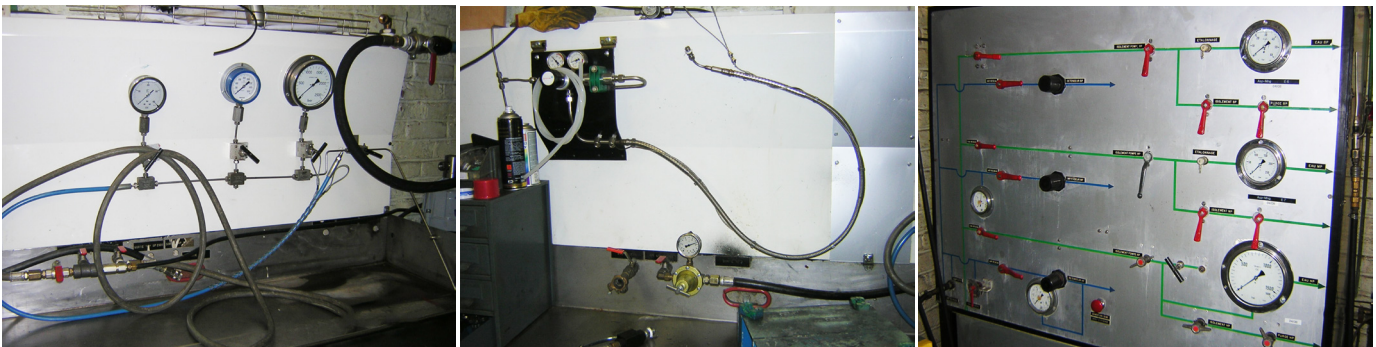

For repair, please send your boosters or pumps to the following address:

PETROMETALIC
11 Rue des Ecluses de Selles
F-59405 CAMBRAI CEDEX
FRANCE
Tel : +33 3 27 72 06 20
Fax : +33 3 27 72 06 31
Email : packers@petrometalic.com

PETROMETALIC



Siège social

32 rue de l'Ermitage
78000 VERSAILLES

Tel : +33 1 39 23 96 70

Fax : +33 1 39 23 96 71



Petrometalic Cambrai

Rue des Ecluses de Selles
BP 287

59400 Cambrai Cedex

Tel : +33 3 27 72 06 60

Fax : +33 3 27 72 06 61

www.petrometalic.com

negoceversailles@petrometalic.com

negocecambrai@petrometalic.com